



SHEARLINE ORIGINAL

MASTER SYSTEM

www.shearline.com

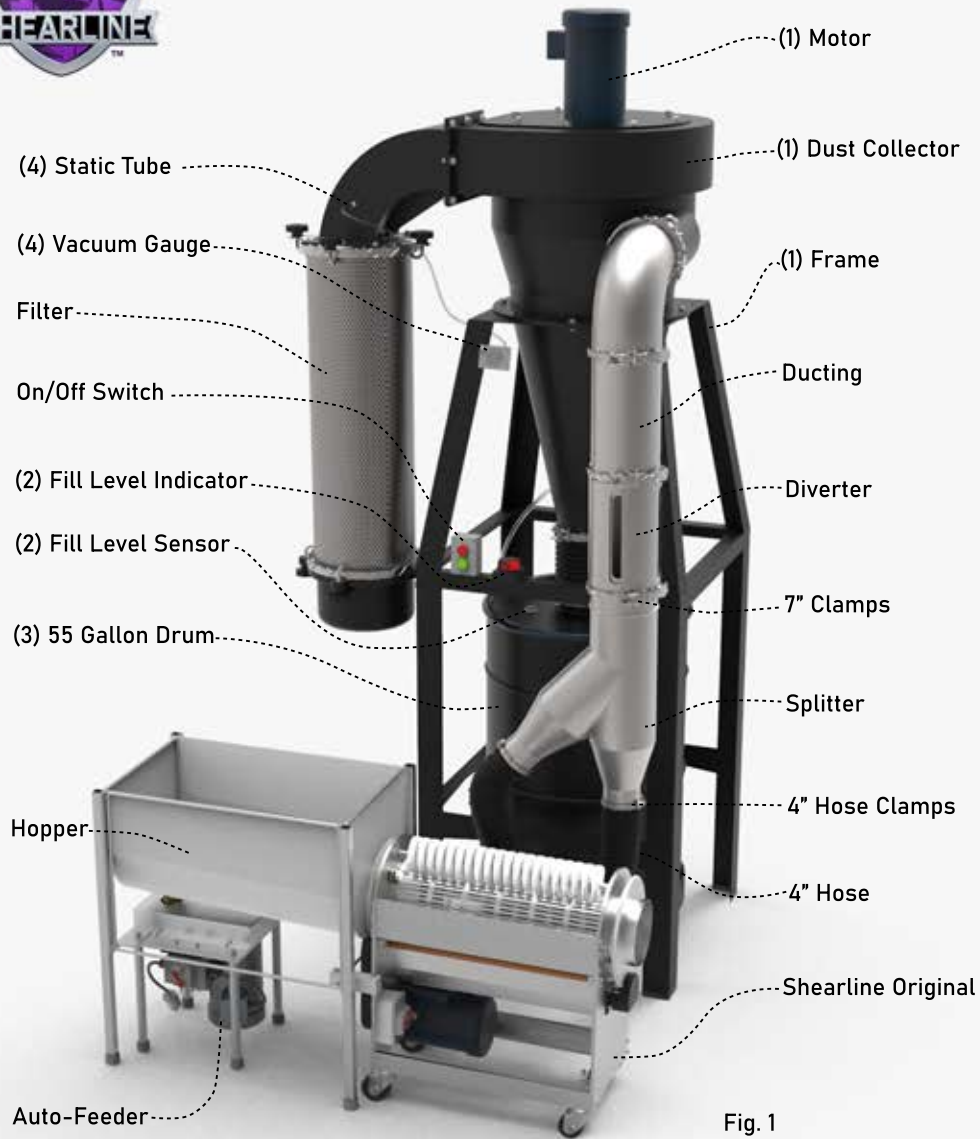

Fig. 1

- 1: Follow instructions included with your model of **Dust Collector***
 - 2: Follow instructions included with **Infrared Dust Sentry Bin Fill Level Indicator Kit***
 - 3: Orient your **FRAME** so that the **55 GALLON DRUM** can be **removed without obstruction**. Note the opening in Fig. 1
 - 4: Follow instructions included with **Real-Time Filter Efficiency Gauge Kit***
- *Instructions for accessories can be found at www.oneida-air.com



Fig. 2

Attach the 4" HOSE to each end of the SPLITTER using the provided 4" HOSE CLAMPS, then attach the other ends to the SQUIRT.
Note: For convenience, the SHEARLINE ORIGINAL may be removed from the system while leaving the SQUIRT attached to the SPLITTER.

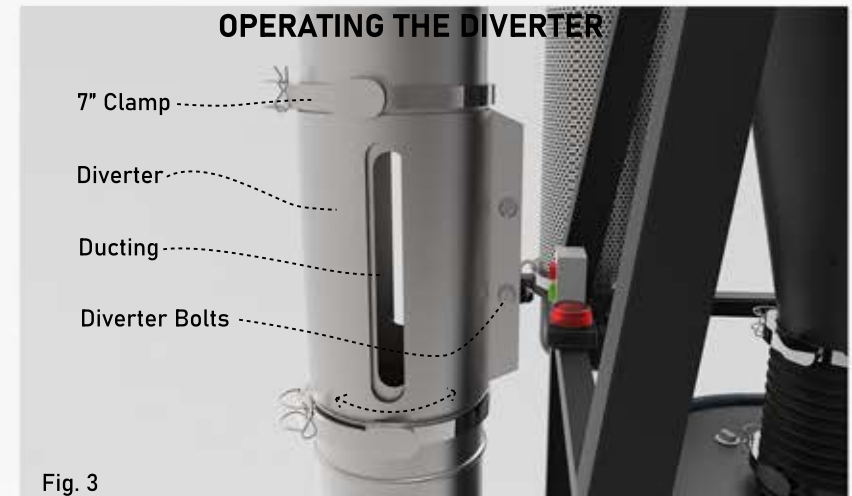

Fig. 3

Depending on your particular strain, the DIVERTER may need adjustment to achieve and maintain optimal airflow. To do this, **loosen** the **two DIVERTER BOLTS** (do not remove) and **rotate** the DIVERTER, **widening** or **narrowing** the slots on the DUCTING, until optimal airflow is achieved, then **retighten** the bolts to ensure the DIVERTER remains fixed.